

# Current Transducer LTS 6-NP

$$I_{PN} = 6 \text{ At}$$

For the electronic measurement of currents : DC, AC, pulsed, mixed, with a galvanic isolation between the primary circuit (high power) and the secondary circuit (electronic circuit).



## Electrical data

$I_{PN}$	Primary nominal r.m.s. current	6	At
$I_P$	Primary current, measuring range	0 .. ± 19.2	At
$\hat{I}_{PDC}$	Overload capability	250	At
$V_{OUT}$	Analog output voltage @ $I_P = 0$	$2.5 \pm (0.625 \cdot I_P / I_{PN})$ $2.5^{1)}$	V V
$N_S$	Number of secondary turns (± 0.1 %)	2000	
$R_L$	Load resistance	≥ 2	kΩ
$R_{IM}$	Internal measuring resistance (± 0.5 %)	208.33	Ω
$TCR_{IM}$	Thermal drift of $R_{IM}$	< 50	ppm/K
$V_C$	Supply voltage (± 5 %)	5	V
$I_C$	Current consumption @ $V_C = 5 \text{ V}$	Typ $28 + I_S^{(2)} + (V_{OUT} / R_L)$	mA

## Accuracy - Dynamic performance data

$X$	Accuracy @ $I_{PN}, T_A = 25^\circ\text{C}$	± 0.2	%
	Accuracy with $R_{IM}$ @ $I_{PN}, T_A = 25^\circ\text{C}$	± 0.7	%
$\epsilon_L$	Linearity error	< 0.1	%
$TCV_{OUT}$	Thermal drift of $V_{OUT}$ @ $I_P = 0$	- 10°C .. + 85°C - 40°C .. - 10°C	Typ 80 Max 200 ppm/K 250 ppm/K
$TCE_G$	Thermal drift of the gain	- 40°C .. + 85°C	50 <sup>3)</sup> ppm/K
$V_{OM}$	Residual voltage @ $I_P = 0$ , after an overload of $3 \times I_{PN}$		± 0.5 mV
	$5 \times I_{PN}$		± 2.0 mV
	$10 \times I_{PN}$		± 2.0 mV
$t_{ra}$	Reaction time @ 10 % of $I_{PN}$	< 100	ns
$t_r$	Response time @ 90 % of $I_{PN}$	< 400	ns
$di/dt$	di/dt accurately followed	> 15	A/μs
$f$	Frequency bandwidth (0 .. - 0.5 dB)	DC .. 100	kHz
	(- 0.5 .. 1 dB)	DC .. 200	kHz

## General data

$T_A$	Ambient operating temperature	- 40 .. + 85	°C
$T_S$	Ambient storage temperature	- 40 .. + 100	°C
	Insulating material group	III a	
$m$	Mass	10	g
	Standards <sup>4)</sup>	EN 50178 : 1997 IEC 60950-1 : 2001	

Notes : 1) Absolute value @  $T_A = 25^\circ\text{C}$ ,  $2.475 < V_{OUT} < 2.525$

2) Please see the operation principle on the other side

3) Only due to  $TCR_{IM}$

4) Specification according to IEC 61000-4-3 are not guaranteed between 95 and 110 MHz (value higher by 5% than the specification).

## Features

- Closed loop (compensated) multi-range current transducer using the Hall effect
- Unipolar voltage supply
- Compact design for PCB mounting
- Insulated plastic case recognized according to UL 94-V0
- Incorporated measuring resistance
- Extended measuring range.

## Advantages

- Excellent accuracy
- Very good linearity
- Very low temperature drift
- Optimized response time
- Wide frequency bandwidth
- No insertion losses
- High immunity to external interference
- Current overload capability.

## Applications

- AC variable speed drives and servo motor drives
- Static converters for DC motor drives
- Battery supplied applications
- Uninterruptible Power Supplies (UPS)
- Switched Mode Power Supplies (SMPS)
- Power supplies for welding applications.

## Application domain

- Industrial.

Copyright protected.

## Current Transducer LTS 6-NP

### Isolation characteristics

$V_d$	R.m.s. voltage for AC isolation test, 50/60 Hz, 1 mn	3	kV
$\hat{V}_w$	Impulse withstand voltage 1.2/50 $\mu$ s	> 8	kV
		Min	
$V_e$	R.m.s. voltage for partial discharge extinction @ 10pC	> 1.5	kV
		Min	
dCp	Creepage distance <sup>5)</sup>	15.5	mm
dCl	Clearance distance <sup>6)</sup>	6.35	mm
CTI	Comparative Tracking Index (Group III a)	175	

### Application examples

According to EN 50178 and IEC 61010-1 standards and following conditions :

- Over voltage category OV 3
- Pollution degree PD2
- Non-uniform field

	EN 50178	IEC 61010-1
dCp, dCl, $\hat{V}_w$	Rated isolation voltage	Nominal voltage
Single isolation	600 V	600 V
Reinforced isolation	300 V	300 V

Notes : <sup>5)</sup> On housing

<sup>6)</sup> On PCB with soldering pattern UTEC93-703.

### Safety



This transducer must be used in electric/electronic equipment with respect to applicable standards and safety requirements in accordance with the following manufacturer's operating instructions.



Caution, risk of electrical shock

When operating the transducer, certain parts of the module can carry hazardous voltage (eg. primary busbar, power supply).

Ignoring this warning can lead to injury and/or cause serious damage.

This transducer is a built-in device, whose conducting parts must be inaccessible after installation.

A protective housing or additional shield could be used.

Main supply must be able to be disconnected.

## Dimensions LTS 6-NP (in mm. 1 mm = 0.0394 inch)

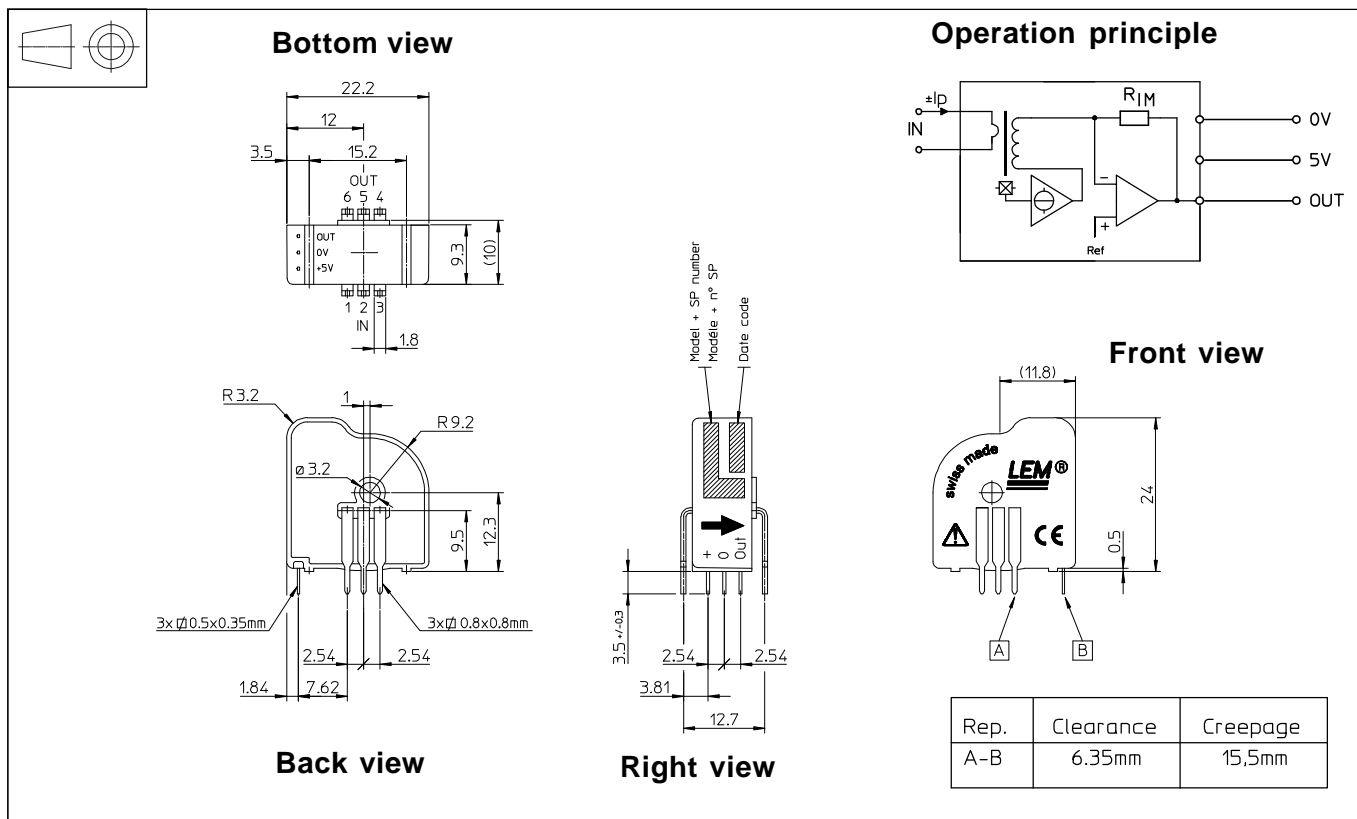

Number of primary turns	Primary nominal r.m.s. current $I_{PN}$ [A]	Nominal output voltage $V_{OUT}$ [V]	Primary resistance $R_p$ [m $\Omega$ ]	Primary insertion inductance $L_p$ [ $\mu$ H]	Recommended connections
1	$\pm 6$	$2.5 \pm 0.625$	0.18	0.013	
2	$\pm 3$	$2.5 \pm 0.625$	0.81	0.05	
3	$\pm 2$	$2.5 \pm 0.625$	1.62	0.12	

### Mechanical characteristics

- General tolerance  $\pm 0.2$  mm
- Fastening & connection of primary 6 pins 0.8 x 0.8 mm  
Recommended PCB hole 1.3 mm
- Fastening & connection of secondary 3 pins 0.5 x 0.35 mm  
Recommended PCB hole 0.8 mm
- Additional primary through-hole  $\varnothing 3.2$  mm

### Remark

- $V_{OUT}$  is positive when  $I_p$  flows from terminals 1, 2, 3 to terminals 6, 5, 4.

### Output Voltage - Primary Current

