

# AUTOMOTIVE CURRENT SENSOR DHAB S/25

## CE Datasheet

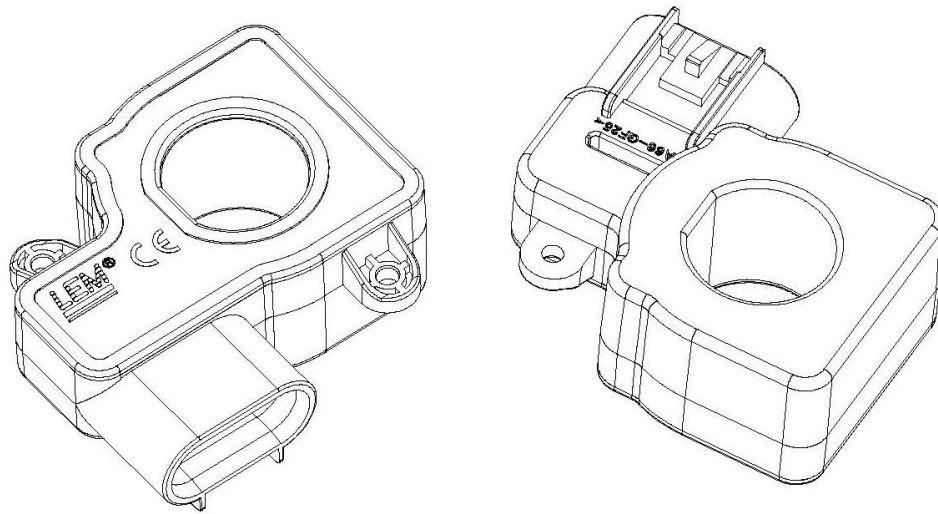

# DHAB S/25

## Introduction

The DHAB family is best suited for DC, AC or pulse current measurement in high power and low voltage automotive applications. It contains a galvanic isolation between the primary circuit (high power) and the secondary circuit (electronic circuit).

The DHAB family has a dual current range. It gives you the choice of having different peak currents (from +/- 20A up to +/- 600A) in the same housing.

## Features

- Open loop transducer using the Hall effect sensor
- Low voltage application
- Unipolar +5VDC power supply
- Primary current measuring range up to ± 100A for range 1 and +/- 600A for range 2
- Maximum rms primary admissible current : defined by primary cable to have  $T^{\circ} < +150^{\circ}C$
- Operating temperature range:  $- 40^{\circ}C < T^{\circ} < +125^{\circ}C$
- Output voltage:
  - fully ratio-metric (gain and offset)
  - 2 measuring ranges to have a better accuracy.

## Advantages

- Good accuracy for high and low current range
- Good linearity
- Low thermal offset drift
- Low thermal gain drift
- Hermetic package.

## Automotive applications

- Battery Pack Monitoring
- Hybrid Vehicles
- EV and Utility Vehicles.

## Principle of the DHAB Family

The open loop transducers use an Hall effect IC. The magnetic induction B, contributing to the rise of the Hall voltage, is generated by the primary current  $I_p$  to be measured. The control current  $I_c$  is supplied by a current source i.e. battery or generator (Fig. 1).

Within the linear region of the hysteresis cycle, B is proportional to:

$$I_p (B) = \text{constant} (a) \times I_p$$

The Hall voltage is thus expressed by:

$$V_H = (K/d) \times l \times \text{constant} (a) \times I_p$$

Except for  $I_p$ , all terms of this equation are constant. Therefore:

$$V_H = \text{constant} (b) \times I_p$$

The measurement signal  $V_H$  amplified to supply the user output voltage or current.

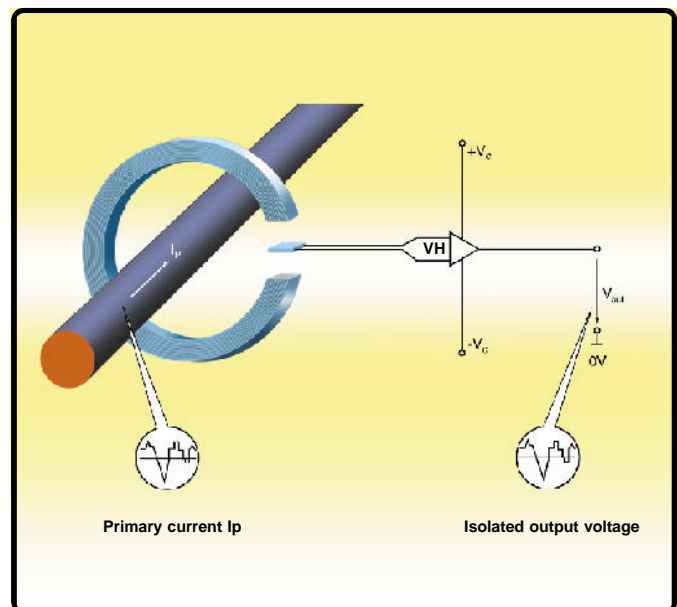
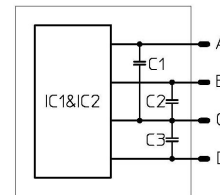
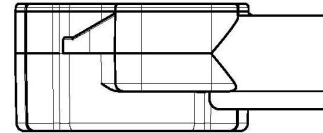
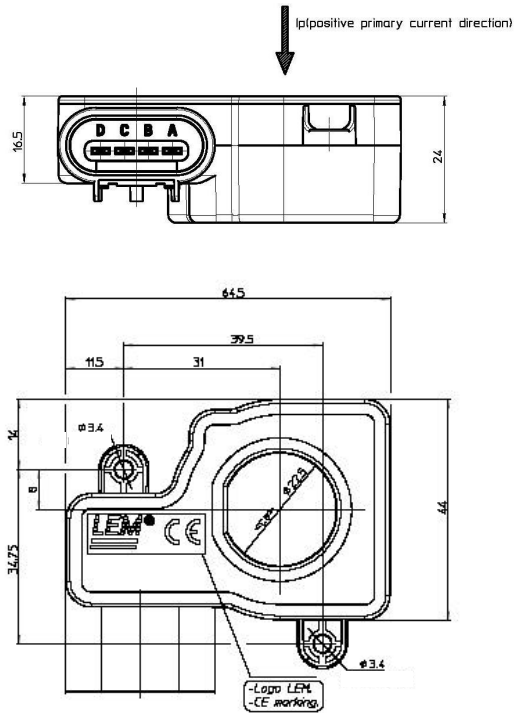

Fig. 1: Principle of the open loop transducer.

# DHAB S/25

Dimensions DHAB S/25 (in mm. 1mm = 0.0394 inch)



Pin out	
A	Channel 2
B	V <sub>c</sub>
C	Gnd
D	Channel 1

-Date code: 1-Product Design Center (GVA),  
 Y-Year  
 DD=Day of the year.  
 HH=Hour.  
 MM=Minute.  
 SS=Second.  
 -DHAB S/xx -sensor name / version.  
 - - - identification code for Jlg.

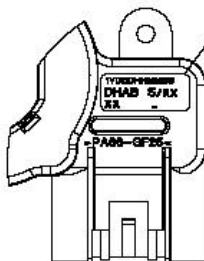

## System Architecture

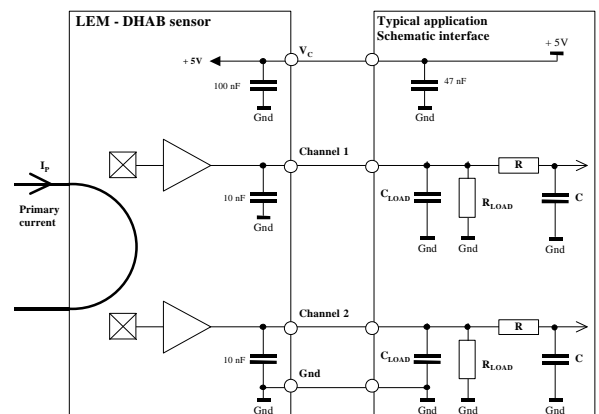

## Bill of materials

- Plastic case
- Pins
- Magnetic core
- Mass

PA 66-GF25  
 Brass tin plated  
 Channel 1: FeNi alloy  
 Channel 2: FeSi alloy  
 69.5 g

$R_{LOAD}$  > 10 k $\Omega$  Optional resistor for signal line diagnostic  
 $C_{LOAD}$  < 100 nF EMC protection  
 RC low pass filter EMC protection (optional)

## DHAB S/25

### Absolute maximum rating (not operating)

PARAMETER	Symbol	Unit	Specification			Conditions
			Mini	Typical	Maxi	
<b>Electrical Data</b>						
Supply continuous over voltage		V			8.5	
Supply over voltage		V			14	1 min
Reverse voltage		V	-14			1 min @ T <sub>A</sub> = 25°C
Output continuous over voltage		V			8.5	
Output over voltage		V			14	1 min @ T <sub>A</sub> = 25°C
Continuous output current	I <sub>out</sub>	mA	-10		10	
Output short circuit duration	t <sub>c</sub>	min			2	
Storage temperature	T <sub>s</sub>	°C	-40		125	

### Operating conditions

PARAMETER	Symbol	Unit	Specification			Conditions
			Mini	Typical	Maxi	
<b>Electrical Data</b>						
Supply voltage	V <sub>C</sub>	V	4.75	5	5.25	
Current consumption	I <sub>C</sub>	mA		15.00	20	
Power up inrush current		mA			40	@ V <sub>C</sub> < 3.5 volts
Continuous output current	I <sub>out</sub>	mA	-1		1	
Load resistor	R <sub>L</sub>	KΩ	10			
Load capacitor	C <sub>L</sub>	nF	1		100	
Ambient operating temperature	T <sub>A</sub>	°C	-10		65	High accuracy
			-40		125	Reduced accuracy

### Channel 1

PARAMETER	Symbol	Unit	Specification			Conditions
			Mini	Typical	Maxi	
<b>Electrical Data</b>						
Primary current, measuring range	I <sub>Pchannel 1</sub>	A	-25		25	
Offset voltage 1)	V <sub>o</sub>	V		2.5		@ V <sub>C</sub> 5 volts
Sensitivity 1)	G	mV/A		80		@ V <sub>C</sub> 5 volts
Resolution	R <sub>L</sub>	mV		2.5		@ V <sub>C</sub> 5 volts
Clamp low 1)		V	0.24	0.25	0.26	@ V <sub>C</sub> 5 volts
Clamp high 1)		V	4.74	4.75	4.76	@ V <sub>C</sub> 5 volts
Output internal resistance	R <sub>OUT</sub>	Ω		1	10	
Frequency bandwidth	BW	Hz		80		@ -3 dB
Power up time		ms			110	
Setting time after over load		ms			25	

### Channel 2

PARAMETER	Symbol	Unit	Specification			Conditions
			Mini	Typical	Maxi	
<b>Electrical Data</b>						
Primary current, measuring range	I <sub>Pchannel 2</sub>	A	-200		200	
Offset voltage 1)	V <sub>o</sub>	V		2.5		@ V <sub>C</sub> 5 volts
Sensitivity 1)	G	mV/A		10		@ V <sub>C</sub> 5 volts
Resolution	R <sub>L</sub>	mV		2.5		@ V <sub>C</sub> 5 volts
Clamp low 1)		V	0.24	0.25	0.26	@ V <sub>C</sub> 5 volts
Clamp high 1)		V	4.74	4.75	4.76	@ V <sub>C</sub> 5 volts
Output internal resistance	R <sub>OUT</sub>	Ω		1	10	
Frequency bandwidth	BW	Hz		80		@ -3 dB
Power up time		ms			110	
Setting time after over load		ms			25	

**Note:** 1) The output voltage V<sub>out</sub> is fully ratio-metric (that concerns V<sub>o</sub>, Sensitivity and clamping), it depends on the supply voltage V<sub>C</sub> in relative with the following formula:

$$I_p = \left( V_{out} - \frac{V_c}{2} \right) \times \frac{1}{G} \times \frac{5}{V_c} \quad \text{With } G \text{ in (V/A)}$$

## DHAB S/25

### Accuracy

#### Channel 1

PARAMETER	Symbol	Unit	Specification			Conditions
			Mini	Typical	Maxi	
<b>Electrical Data</b>						
Electrical offset current	$I_{OEchannel1}$	mA		±60		@ $T_A = 25^\circ\text{C}$
Residual current	$I_{OMchannel1}$	mA		±50		@ $T_A = 25^\circ\text{C}$
Global offset current	$I_{Ochannel1}$	mA		±110		@ $T_A = 25^\circ\text{C}$
			-300		300	@ $-10^\circ\text{C} < T^\circ < 65^\circ\text{C}$
			-500		500	@ $-40^\circ\text{C} < T^\circ < 125^\circ\text{C}$
Sensitivity error	$\varepsilon_G$	%		±0.5		@ $T_A = 25^\circ\text{C}$
			-2.5		2.5	@ $-10^\circ\text{C} < T^\circ < 65^\circ\text{C}$
			-4		4	@ $-40^\circ\text{C} < T^\circ < 125^\circ\text{C}$
Linearity error	$\varepsilon_L$	%	-1.0		1.0	of full range

#### Channel 2

PARAMETER	Symbol	Unit	Specification			Conditions
			Mini	Typical	Maxi	
<b>Electrical Data</b>						
Electrical offset current	$I_{OEchannel2}$	A		±0.5		@ $T_A = 25^\circ\text{C}$
Residual current	$I_{OMchannel2}$	A		±1.5		@ $T_A = 25^\circ\text{C}$
Global offset current	$I_{Ochannel2}$	A		±2.0		@ $T_A = 25^\circ\text{C}$
			-4.0		4.0	@ $-10^\circ\text{C} < T^\circ < 65^\circ\text{C}$
			-4.5		4.5	@ $-40^\circ\text{C} < T^\circ < 125^\circ\text{C}$
Sensitivity error	$\varepsilon_G$	%		±0.5		@ $T_A = 25^\circ\text{C}$
			-2.5		2.5	@ $-10^\circ\text{C} < T^\circ < 65^\circ\text{C}$
			-4		4	@ $-40^\circ\text{C} < T^\circ < 125^\circ\text{C}$
Linearity error	$\varepsilon_L$	%	-1.0		1.0	of full range

**Note:** In case of short circuit of any DHAB output to + batt, a current is reinjected in the power supply. If the output voltage is not protected against this current, this voltage may increase or decrease, which must be taken into account for the second channel.

# DHAB S/25

## PERFORMANCE PARAMETERS DEFINITIONS

### Sensitivity:

The Transducer's sensitivity **G** is the slope of the straight line

$V_{out} = f(I_p)$ , it must establish the relation:

$$V_{out}(I_p) = V_C/5 (G \times I_p + 2.5) (*)$$

(\*) For all symetrics transducers.

### Output voltage:

It's the output voltage when the primary current is null. The ideal value of  $V_o$  is  $V_C/2$ . So, the difference of  $V_o - V_C/2$  is called the total offset voltage error. This offset error can be attributed to the electrical offset (due to the resolution of the ASIC quiescent voltage trimming), the magnetic offset, the thermal drift and the thermal hysteresis.

### Magnetic offset:

The magnetic offset is the consequence of an over-current on the primary side. It's defined after an excursion of  $I_{Pmaxi}$ .

### Linearity:

The maximum positive or negative discrepancy with a reference straight line  $V_{OUT} = f(I_p)$ .

Unit: linearity [%] expressed with full scale of  $I_{Pmaxi}$ .

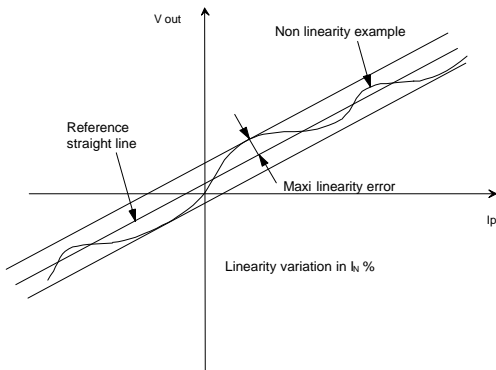

### Response time (delay time) $t_r$ :

The time between the primary current signal and the output signal reach at 90 % of its final value

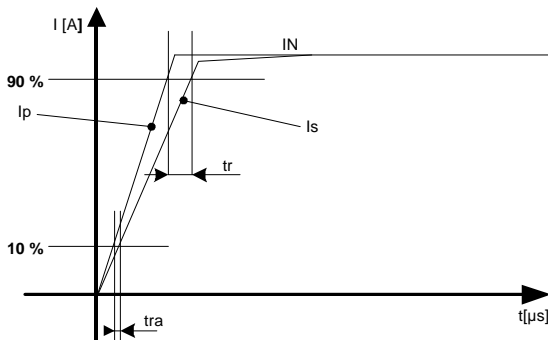

### Output noise voltage:

The output voltage noise is the result of the noise floor of the Hall elements and the linear  $I_C$  amplifier sensitivity.

### Offset drift:

The error of the offset in the operating temperature  $\epsilon_{Offset}$  is the relative variation of the offset in the temperature considered with the initial offset at 25°C. The offset temperature coefficient  $TCV_{OE}$  ( $TCI_{OE}$ ) in the operating temperature is the slope of  $\epsilon_{Offset} = f(T)$ .

### Sensitivity drift:

The error of the sensitivity in the operating temperature Sensitivity Error is the relative variation of the sensitivity in the temperature considered with the initial sensitivity at 25°C. Sensitivity temperature coefficient  $TCE_G$ .

### Typical:

Theoretical value or usual accuracy recorded during the production.

### Environmental test specifications

NAME	STANDARD	CONDITIONS
Low T° storage	TBD	
Thermal shocks	IEC 60068 Part 2-14	T° - 40°C to 120°C /300 cycles not connected
Low T° operation at mini supply voltage	TBD	T° - 40°C / 1000 H supply voltage = 4.75 V
Hight T° operation at maxi supply voltage	IEC 60068 Part 2-2	T° 125°C / 1000 H supply voltage = 5.25 V
Temperature humidity bias	IEC 60068 Part 2-3	T° 90°C / 95 % RH/ 1000 H supply voltage = 5.25 V
<b>Mechanical Tests</b>		
Vibration	TBD	Acceleration 30m/s <sup>2</sup> , 25°C, frequency 20 to 1000 Hz/8h each axis
Drop test	IEC 60068 Part 2-29	Drop 1m, 2 falls/part, 1part/axis, 3axes, criteria : relative sensitivity error 3%
<b>EMC Test</b>		
Rms voltage for AC isolation test	TBD	
Bulk current injected-radiated immunity	ISO11452-4	
Electrostatic discharge	TBD	

Deviation of the typical global accuracy after the environmental tests:

	@ $I_p = 0 A$	@ $\pm I_p$
$T_A = 25^\circ C$	TBD	TBD
(-) $40^\circ C < T^\circ < 125^\circ C$	TBD	TBD