

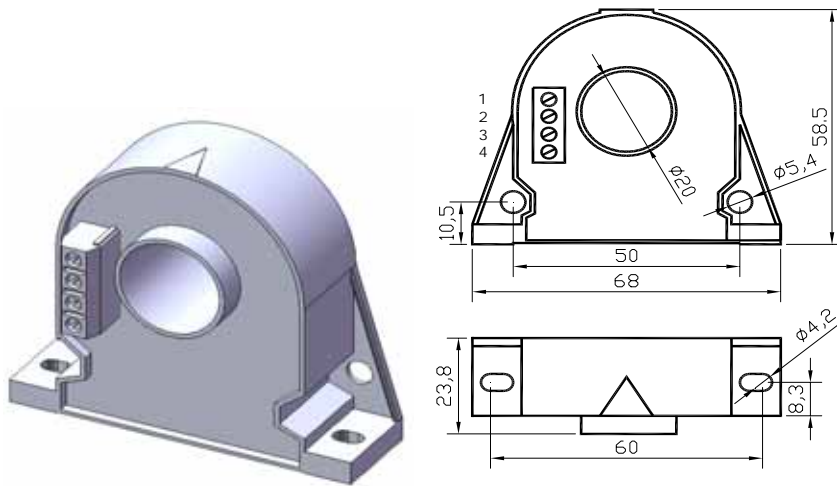

MS-HIB200 Current Transducer

Product Introduction:

Current Transducer is a that, has been measured current non-anamorphic transfer to measurement module of output current in term of linearity proportion, primary side、 secondary side high insulation, isolation measurement non-insert ullage, high precision degree, high linearity degree, high integration degree, little cubage, simple configuration, tranquilization of long-term work and suit in variety of work environment.



definition of connection end
End 1: power supply anode
End 2: power supply cathode
End 3: output of signal anode
End 4: input of signal cathode

Major Application:

Alternating Current frequency conversion timing、 waiting for electricity machine traction、 Direct Current electricity machine、 measurement of in variety of power supply equipment and control、 electric welding machine.

- Measurement for Alternating Current、 Direct Curren and Mpulse
- Response time quickly
- Non-insert abrasion
- Excellent linearity degree of full-extent
- Strong ability of over loading
- Strong ability of anti-jamming

北京铭晟嘉业电子科技有限公司
Beijing EFE Electronic Technology CO., LTD

Product Description:

Product type: MS-HIB200

Rating input of virtual value current of primary side: 0-200A (0...100KHz)

Mode of current measurement: Φ 20mm measurement of perforation style

Rating output virtual value current of primary side: 0-100mA (0...100KHz)

Power supply: DC \pm 12V& DC \pm 15V

Current Reference:

Current of primary side measurement range: 0-300A (0...100KHz)

Transform Rate: 1 : 2000

Measurement Accuracy: 0.8% & 0.5%

Linearity Accuracy: 0.2%

Response Time: t_r 1 μ S@100% of I_{pMAX}

Current Maladjustment: I_o \pm 0.2mA @ $T_A=25$

Error of stagnant magnetism: I_{OM} \pm 0.1mA @ $I_P=0A$

Temperature excursion: I_o 0.020%/

Ability of cincture record: $R_M=0-75\Omega$

Compression resistance of work frequency: input/output/crust AC3.0KV ; 1mA /min

Power supply consume: output current \pm 30mA (power supply DC \pm 15V)

General Reference:

Mode of connection: lead connection of plug end

Work temperature: (-10...+70)

Work humidity: (10-90%) non-coagulation

Counteract resistance of primary side loop: 11 Ω @ $T_A=70$

Memory temperature: (-25...+80)

Material of crust: accord with UL94-V0

Execution standard: EN50178

Notice Proceeding:

Lead must be correct connection between power supply, input and output, location or connection can not error, otherwise maybe induce product dilapidation.

Arrowhead direction is current direction of anode, installation of product, use entironment should non-electric atomy and causticity, altitude should under 2500 meters.

Should contact with factory first, before adjustment product potentiometer, please do not optional adjustment by user, exquisite shake or high temperature be likely to induce product dilapidation, also.

北京铭晟嘉业电子科技有限公司

电话 : 010-84505057 / 84505776

传真 : 010-84505019

电子邮件 : SMI@bjefe.com

Beijing EFE Electronic Technology Co., Ltd

Tel: 010-84505057 / 84505776

Fax: 010-84505019

网址 : www.bjefe.com